

## Xerafy Xplorer tag installation guide

### General Information

This user guide provides instructions for attaching Xerafy Xplorer RFID tags onto drill pipes. Downhole drilling and sub-sea operations require the tag to sustain the high-temperature, high-pressure conditions, severe vibrations and chemical resistance. To achieve the best tag performance, proper installation of the Xplorer tag is critical.

### Xplorer Dimensional Drawing

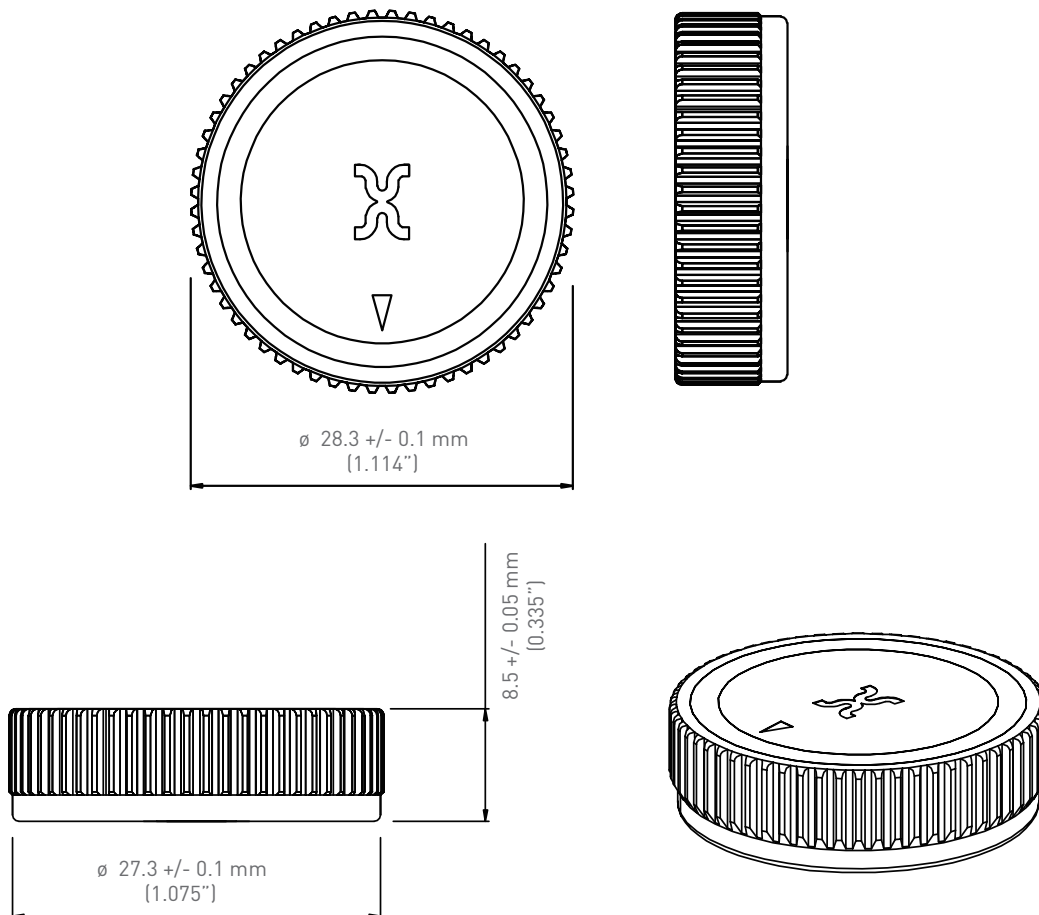

## Embed Pocket Drawing

Step 1: Create a flat surface sized to the recommended dimensions on the connect part of the drill pipe by using the milling machine.

Step 2: Chamfer the length edge of the flat surface. This could help to reduce the wear during pipe drilling.

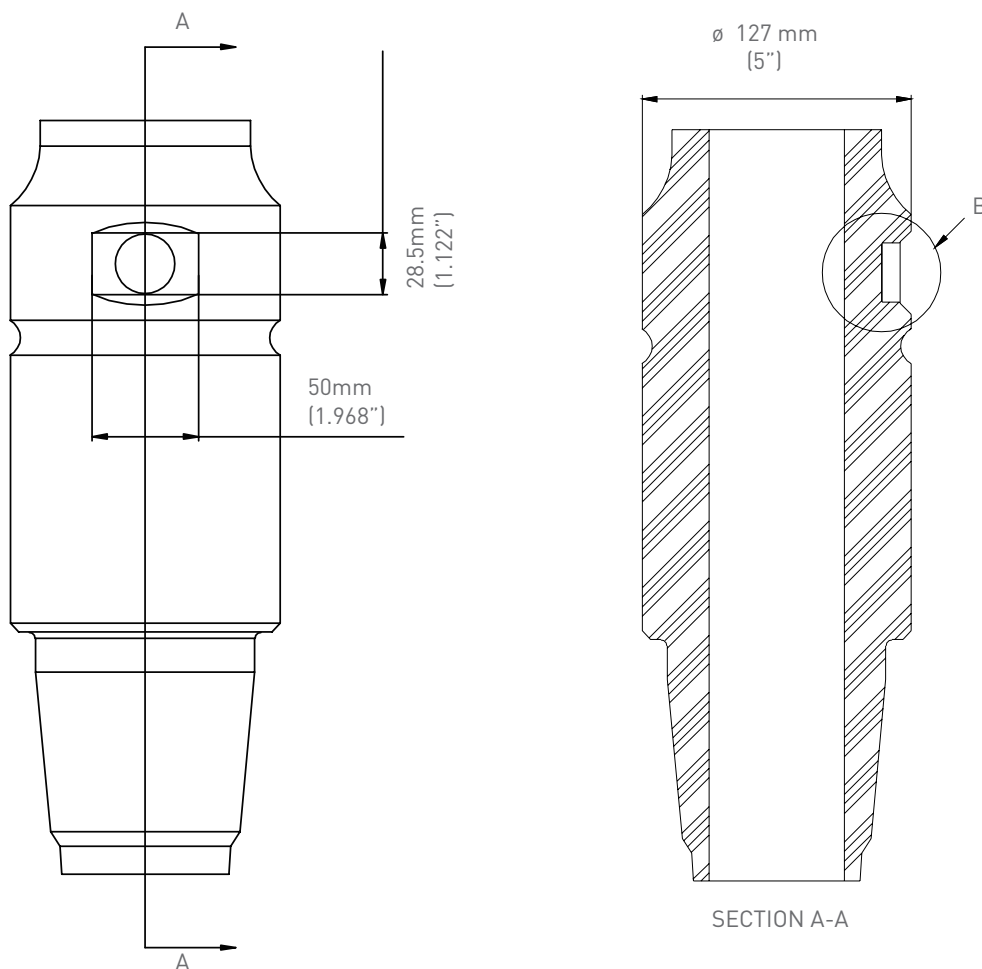

## Embed Pocket Drawing

Step 3: Drill a blind hole in the center of the flat surface at the recommended diameter and depth by drilling machine.

Step 4: Clean the hole.

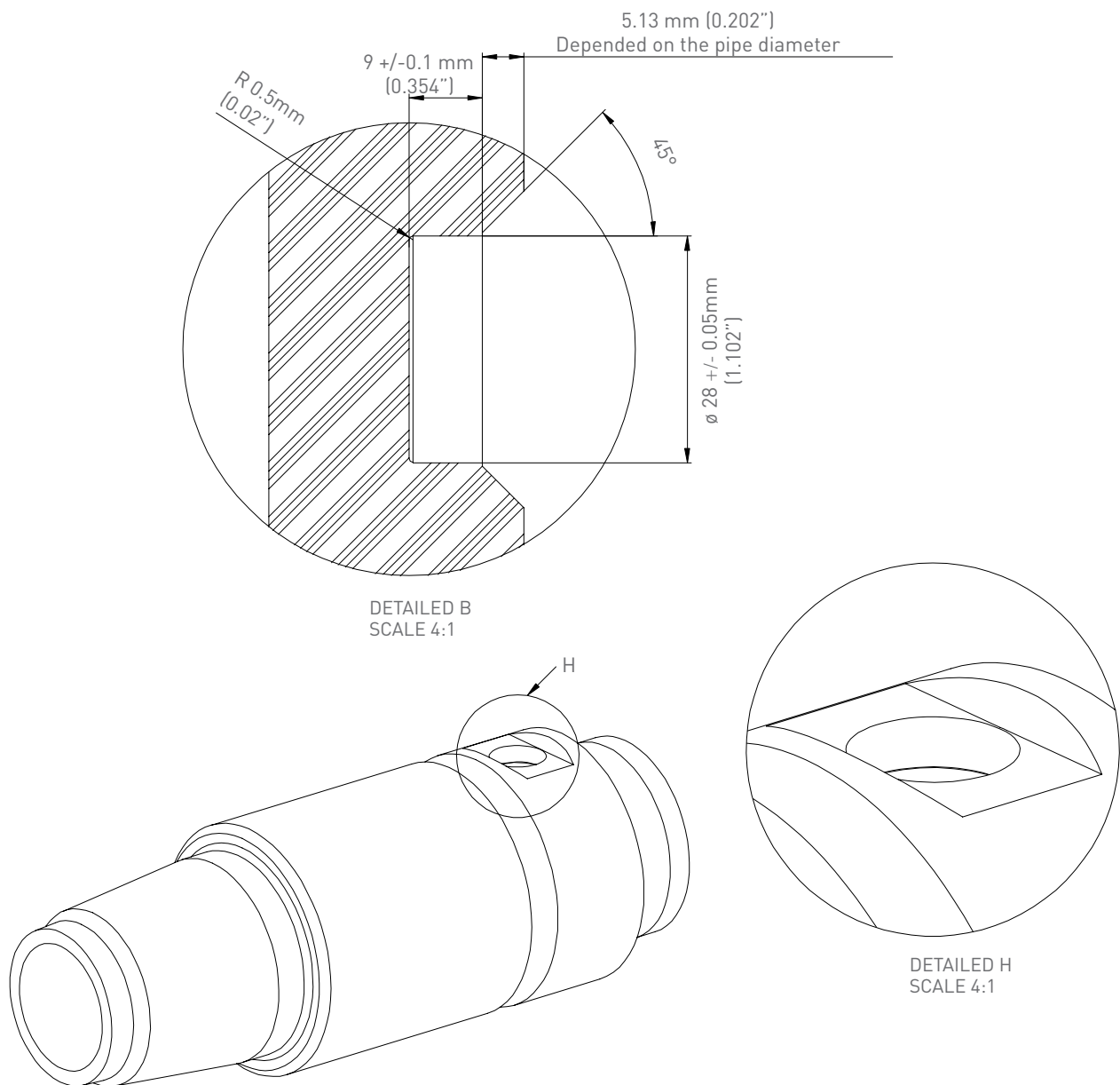

## Driver Tool Drawing

Xerafy strongly recommends creating a recess at the head of the driver tool at the recommended dimensions. This is to protect the Xplorer tag during the pressing process.

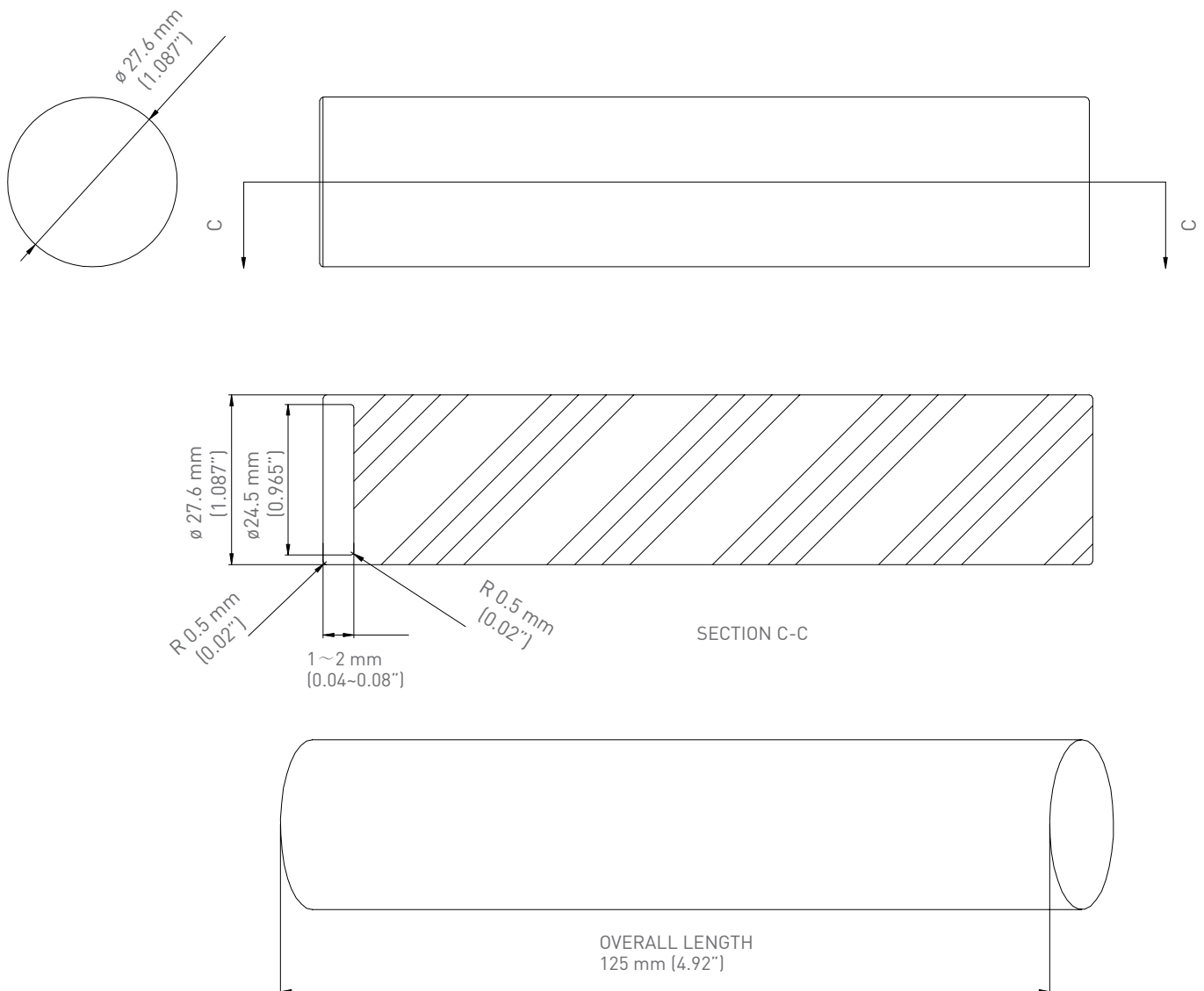

## Installation Steps

Step 1: Ensure the pipe is drilled to the required dimensions and specifications and the drilled hole is free of debris.

Step 2: Place the Xplorer tag onto the asset near the hole with the logo side facing up. For maximum reading range, orient the Xplorer as specified in Step 1. Use finger on the tag to slide it into the position. When nested in the position, the tag will drop down slightly. At that point it is nested, ready to be press-fitted.

Step 3: Use a press, such as an arbor press or a drill-press, and chuck the driver tool in the press (Step not shown).

Step 4: Visually align the asset and nested Xplorer with the driver tool.

Step 5: Use the press to install the Xplorer until it is 0.5 mm below the pipe surface (Step not shown).

Mark need to face to longer free metal surface side for proper reading function

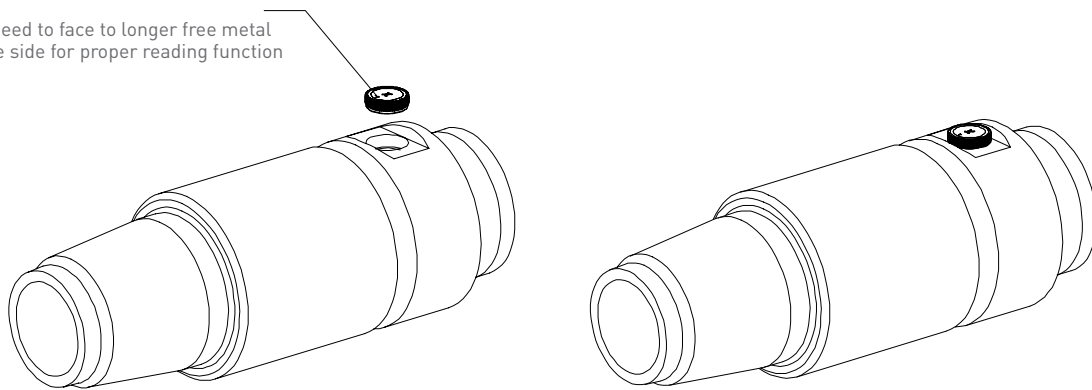

**STEP1**

**STEP2**

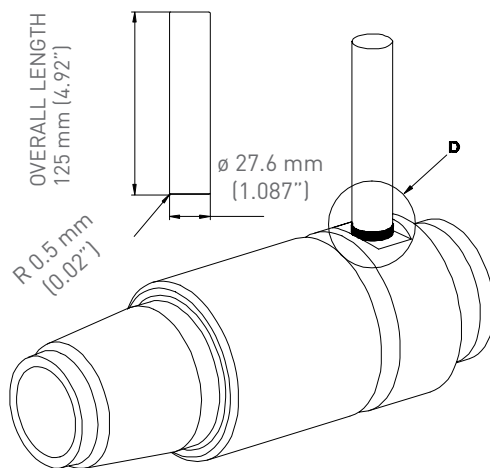

**STEP4**

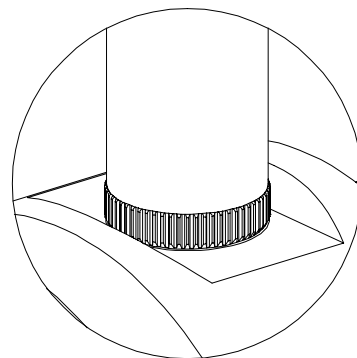

DETAILED D  
SCALE 4:1

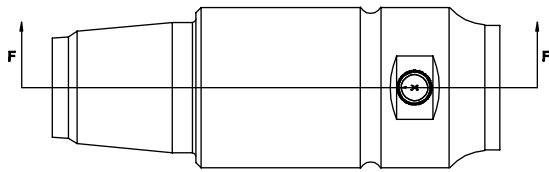
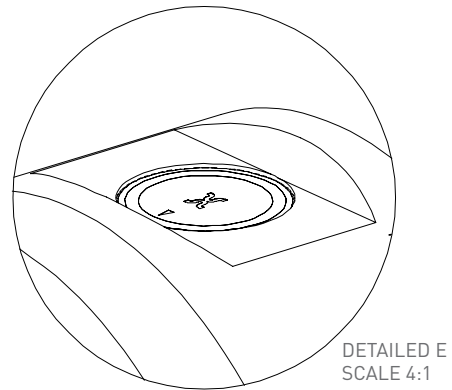
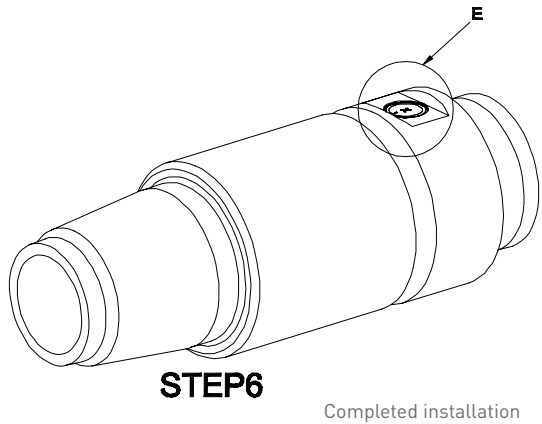

SECTION F-F

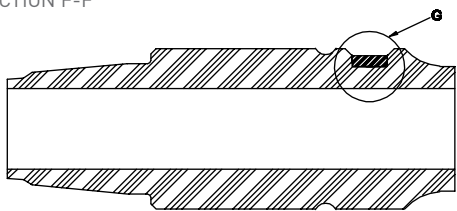

Xplorer should be slightly lower than the pipe surface for proper protection

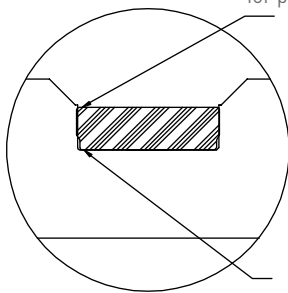

DETAILED G  
SCALE 4:1

Xplorer should be fully inserted to bottom of the hole for proper protection

Step6: Visually inspect the installation for full insertion and perform reading test.

Additional notes:

- Ensure the driving face of the tool is flat, smooth and square. Recommended materials are stainless steel, copper.
- Xerafy strongly recommends using a recessed hole at the head of the driver tool to avoid any potential damage.
- Extraction: an installed Xplorer tag can be removed without damaging the installation hole. The following procedure can be used with flush and recessed installations:
  1. Drill through the center of the laser logo surface of the tag using a 1" diameter, flat bottom, high-speed steel standard end mill. Visually center the cutter and cut 6.5mm deep.
  2. Using a punch and hammer, carefully break up the ceramic core. Intermittently clear and loosen particles using a vacuum or compressed air. Be sure to wear protective eyewear and clothing.
  3. Once the plastic core is removed, tap a T-45(torx) screw driver or bit into the remaining cavity.
  4. If the hole is to be used to embed another tag, please measure the diameter of the hole to ensure the hole still meets the required dimension and tolerance.
  5. Xerafy does not recommend reusing the hole.